

Omega – Axially split Volute Casing Pump

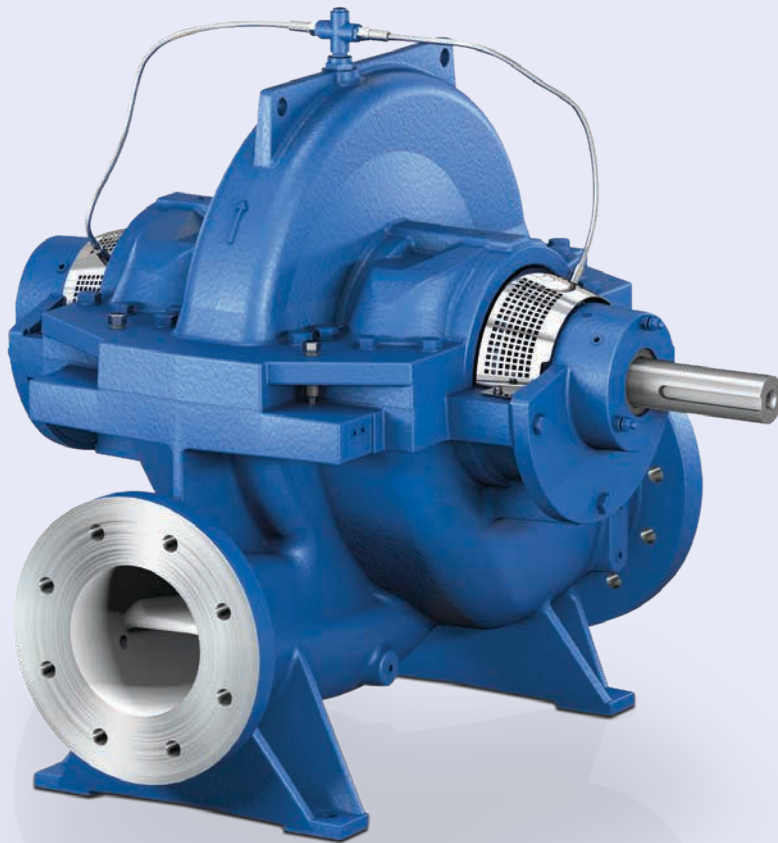

Applications:

For handling pure, raw and waste water as well as seawater in

- Water works
- Irrigation and drainage pumping stations
- Power stations
- Industrial water supply
- Fire fighting systems
- Marine and offshore engineering
- General applications in the petrochemical industry
- Seawater desalination

More information: www.ksb.com

Systems for monitoring pump condition



KSB Guard



PumpMeter

Omega – Axially split Volute Casing Pump

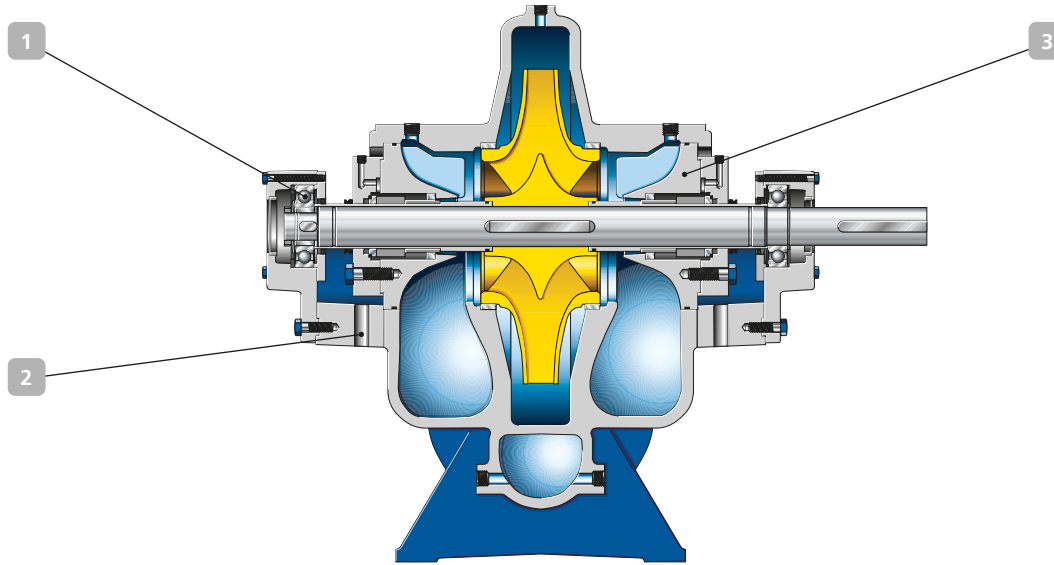

1 High operating reliability

Thanks to the double-entry impeller (compensating the axial forces) the load on the generously dimensioned, pre-loaded, maintenance-free bearings is minimal.

2 Low maintenance costs

- The combination of solid bearing brackets, a short and rigid shaft, and pre-loaded bearings guarantees low vibrations and long operating lives of bearings, seals and coupling.
- Corrosion and abrasion resistant materials ensure top service lives for shaft protecting sleeves, impeller/casing wear rings, and impeller.

3 Service-friendly design

- The self-centring upper part of the casing and the preloaded rotor enable cover and rotor assembly without any adjustments.
- For maintenance, the cover's hexagon head bolts are completely removed from the casing. The casing split flange can therefore be easily and thoroughly cleaned, and the inside of the pump is freely accessible.

Reliable sealing

The solid casing split flange at the upper and lower casing part ensures reliable and trouble-free sealing of the upper and lower casing halves.

Materials*

Volute casing	Grey cast iron/nodular cast iron / duplex cast steel
Impeller	Bronze/duplex cast steel
Shaft	Cr steel/duplex steel
Shaft protecting sleeves	Cr steel
Casing wear rings	Bronze /CR steel
Impeller wear rings (optional)	Bronze /duplex steel

* Other materials on request

Technical data

Pump sizes	DN 80 – 400	3 to 15 in
Capacity	Up to 4,400 m ³ /h	Up to 19,375 gpm
Discharge head	Up to 210 m	Up to 689 ft
Operating pressure	Up to 25 bar	Up to 363 psi
Temperature	0 up to 140 °C	32 up to 284 °F
Automation available		



KSB SE & Co. KGaA
Johann-Klein-Straße 9
67227 Frankenthal (Germany)
www.ksb.com